

## ➡ ASME B16.47 series B flange

### ▶ Class 150 Welding Neck Flanges

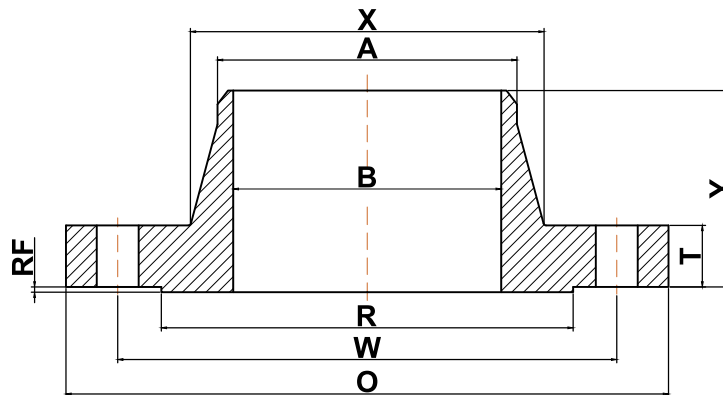

Nominal Pipe Size	Outside Diameter (O)	Bolt Circle (W)	Raised Face Diameter (R)	Number of Holes	Diameter of Holes	Bore (B)	Top of Hub (A)	Hub Diameter (X)	Minimum Fillet Radius (r)	Maximum Thickness (T)	Length Thru Hub (Y)	Approximate Weight (lbs)
26	30.94	29.31	28.00	36	0.88	Specified by purchaser	26.06	26.94	0.38	1.62	3.50	120
28	32.94	31.31	30.00	40	0.88	Specified by purchaser	28.06	28.94	0.38	1.75	3.75	140
30	34.94	33.31	32.00	44	0.88	Specified by purchaser	30.06	31.00	0.38	1.75	3.94	150
32	37.06	35.44	34.00	48	0.88	Specified by purchaser	32.06	33.06	0.38	1.81	4.25	170
34	39.56	37.69	36.25	40	1.00	Specified by purchaser	34.06	35.12	0.38	1.94	4.34	210
36	41.62	39.75	38.25	44	1.00	Specified by purchaser	36.06	37.19	0.38	2.06	4.62	240
38	44.25	42.12	40.25	40	1.12	Specified by purchaser	38.12	39.25	0.38	2.12	4.88	290
40	46.25	44.12	42.50	44	1.12	Specified by purchaser	40.12	41.31	0.38	2.19	5.06	310
42	48.25	46.12	44.50	48	1.12	Specified by purchaser	42.12	43.38	0.44	2.31	5.25	345
44	50.25	48.12	46.50	52	1.12	Specified by purchaser	44.12	45.38	0.44	2.38	5.38	370
46	52.81	50.56	48.62	40	1.25	Specified by purchaser	46.12	47.44	0.44	2.44	5.69	435
48	54.81	52.56	50.75	44	1.25	Specified by purchaser	48.12	49.50	0.44	2.56	5.88	480
50	56.81	54.56	52.75	48	1.25	Specified by purchaser	50.12	51.50	0.44	2.69	6.06	520
52	58.81	56.56	54.75	52	1.25	Specified by purchaser	52.12	53.56	0.44	2.75	6.19	550
54	61.00	58.75	56.75	56	1.25	Specified by purchaser	54.12	55.62	0.44	2.81	6.38	620
56	63.00	60.75	58.75	60	1.25	Specified by purchaser	56.12	57.69	0.56	2.88	6.56	650
58	65.94	63.44	60.75	48	1.38	Specified by purchaser	58.12	59.69	0.56	2.94	6.88	780
60	67.94	65.44	63.00	52	1.38	Specified by purchaser	60.12	61.81	0.56	3.00	7.06	850

(A) All dimensions are in inches

(B) These flanges will be furnished with a 1/16" raised face unless otherwise specified.

(C) Standard Bore will be furnished unless otherwise specified.