

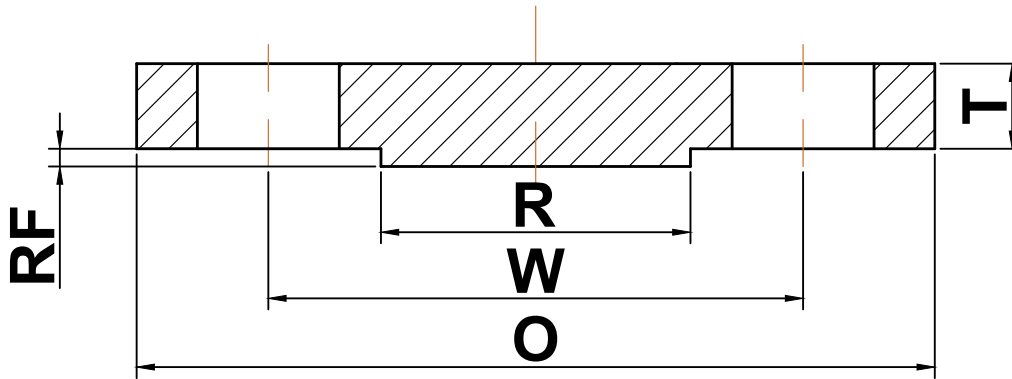

ANSI b16.5

▶ Class 1500 Blind Flanges



Nominal Pipe Size	Outside Diameter (O)	Bolt Circle (W)	Raised Face Diameter (R)	Number of Holes	Diameter of Holes	Thickness (T)	Approximate Weight (lbs)
1/2	4.75	3.25	1.38	4	0.88	0.88	4
3/4	5.12	3.50	1.69	4	0.88	1.00	6
1	5.88	4.00	2.00	4	1.00	1.12	8
1 1/4	6.25	4.38	2.50	4	1.00	1.12	9
1 1/2	7.00	4.88	2.88	4	1.13	1.25	13
2	8.50	6.50	3.62	8	1.00	1.50	25
2 1/2	9.62	7.50	4.12	8	1.13	1.62	35
3	10.50	8.00	5.00	8	1.25	1.88	48
4	12.25	9.50	6.19	8	1.38	2.12	73
5	14.75	11.50	7.31	8	1.63	2.88	140
6	15.50	12.50	8.50	12	1.50	3.25	160
8	19.00	15.50	10.62	12	1.75	3.62	300
10	23.00	19.00	12.75	12	2.00	4.25	510
12	26.50	22.50	15.00	16	2.13	4.88	690
14	29.50	25.00	16.25	16	2.38	5.25	975
16	32.50	27.75	18.50	16	2.63	5.75	1300
18	36.00	30.50	21.00	16	2.88	6.38	1750
20	38.75	32.75	23.00	16	3.13	7.00	2225
24	46.00	39.00	27.25	16	3.63	8.00	3625

(a) All dimensions are in inches

(b) These flanges will be furnished with a 1/4" raised face unless otherwise specified.