

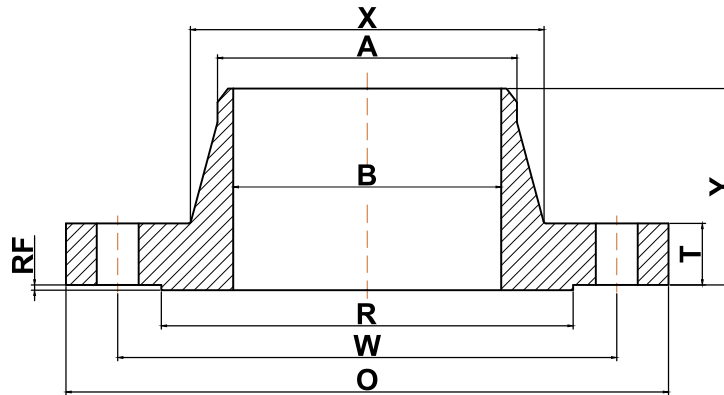

➔ ASME B16.47 series B flange

▶ Class 900 Welding Neck Flanges



Nominal Pipe Size	Outside Diameter (O)	Bolt Circle (W)	Raised Face Diameter (R)	Number of Holes	Diameter of Holes	Bore (B)	Top of Hub (A)	Hub Diameter (X)	Minimum Fillet Radius (r)	Minimum Thickness (T)	Length Thru Hub (Y)	Approximate Weight (lbs)
26	40.25	35.50	30.00	20	2.62	Specified by purchaser	26.00	29.25	0.44	5.31	10.19	1050
28	43.50	38.25	32.25	20	2.88	Specified by purchaser	28.00	31.38	0.50	5.81	10.88	1520
30	46.50	40.75	34.50	20	3.12	Specified by purchaser	30.00	33.50	0.50	6.12	11.38	1820
32	48.75	43.00	36.50	20	3.12	Specified by purchaser	32.00	35.75	0.50	6.31	11.94	2065
34	51.75	45.50	39.00	20	3.38	Specified by purchaser	34.00	37.88	0.56	6.75	12.56	2450
36	53.00	47.25	40.50	24	3.12	Specified by purchaser	36.00	40.00	0.56	6.81	12.81	2520
38	57.50	50.75	43.25	20	3.62	Specified by purchaser	38.00	42.25	0.75	7.50	13.88	3385
40	59.50	52.75	45.75	24	3.62	Specified by purchaser	40.00	44.38	0.81	7.75	14.31	3620
42	61.50	54.75	47.75	24	3.62	Specified by purchaser	42.00	46.31	0.81	8.12	14.62	3960
44	64.88	57.62	50.00	24	3.88	Specified by purchaser	44.00	48.62	0.88	8.44	15.38	4300
46	68.25	60.50	52.50	24	4.12	Specified by purchaser	46.00	50.88	0.88	8.88	16.18	4640
48	70.25	62.50	54.50	24	4.12	Specified by purchaser	48.00	52.88	0.94	9.19	16.50	4980

(a) All dimensions are in inches

(b) These flanges will be furnished with a 1/4" raised face unless otherwise specified.